

# EDDA®

PACKING MACHINES

## SPINNER 1500 s BN

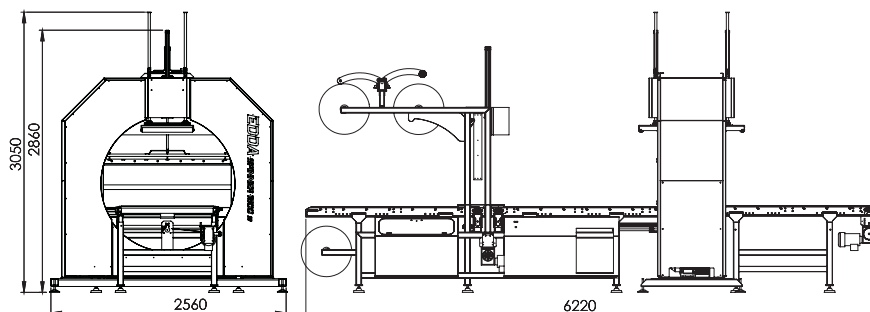
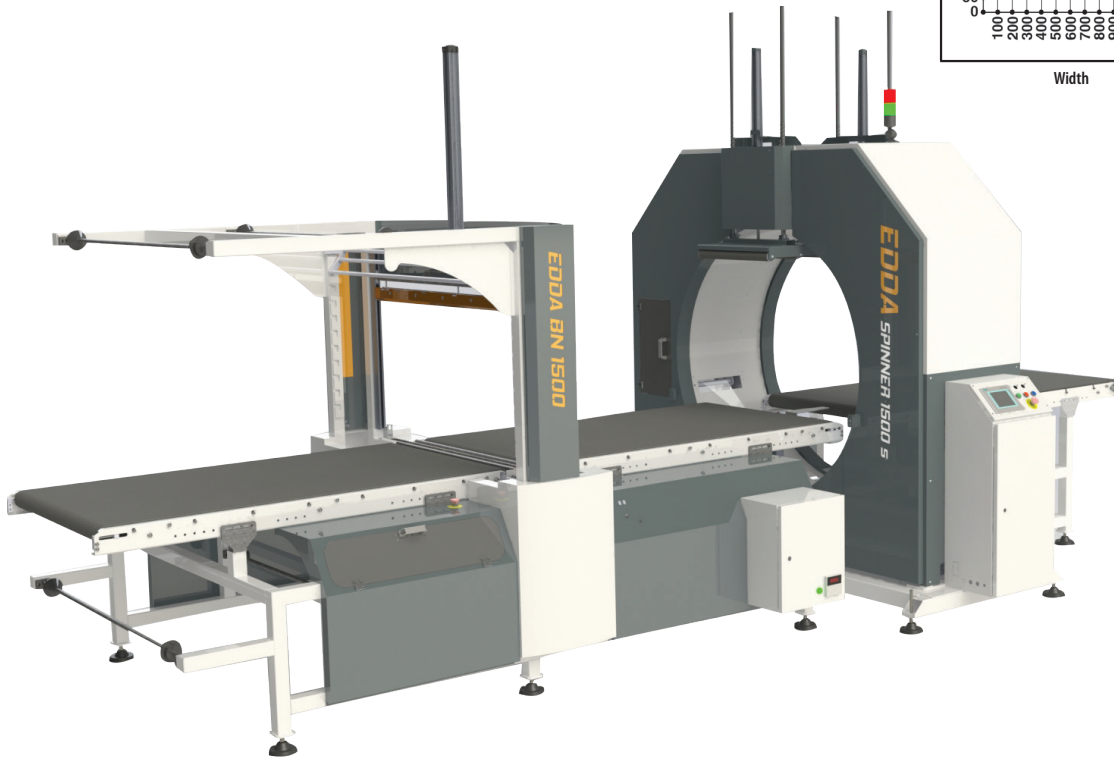
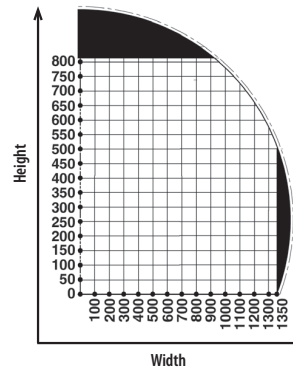

### Perfect for the wrapping;

- \* Bedroom Furniture
- \* Bed Bases
- \* Membrane, acrylic and lacquer painted covers
- \* Bathrooms and kitchen cabinets
- \* Doors
- \* Door frames and mouldings
- \* Laminate flooring
- \* Sandwich panels
- \* Wood Panels
- \* Aluminum, steel and wood profiles and pipes
- \* PVC profile products etc.

### TECHNICAL FEATURES;

#### Product to Wrap Sizes

Max. Length	Unlimited
Min. Length (Width x Height x Length)	100 x 18 x 550*
*With Short Part Nail	

#### Conveyor Belt's Features ;

Useful Length	1924 mm
Total Length	2000 mm
Working Height	900 mm
Electric Motor Power	0,75 kW
Max. Speed	10 m/min
Max. Load Capacity	150 kg/meter

#### Stretchfilm Features;

Max. Width	250 mm
Max. Diameter	250 mm
Reel Core Diameter	76 mm
Recommended Film Thickness	23, 30, 35 micron

#### Machine General Features;

Main Motor Power	2,2 kW
Max. Ring Rotation Speed	50 rpm
Min. Ring Rotation Speed	10 rpm
Electronic Control Components	Siemens, Schneider, LS
Total Weight	1600 Kg

#### Air Bubble Film Unit

Max. Film Width	1350 mm
Max. Film Reel Diameter	700 mm
Reel Core Diameter	20~76 mm
Suitable Film Materials	PE Film, PE Air Bubble Film, PE Foam Film, PVC Film
Cutting System Operating Temperature	50 °C ~ 150 °C