

Shanklin® Automatic Intuitive L-Sealers

Shrink Packaging Machinery

Consistent
Quality,
Performance,
and Reliability



SHANKLIN® SPECIFICATIONS

AUTOMATIC INTUITIVE L-SEALER MODEL

	Models A-26i & A-26i DA	Model A-27i & A-27i DA
Seal Size*	15"W x 21"L	21"W x 33"L
Max. Product Height	• 5.5"	• 7.5" standard • 9.5" with optional 10" height kit
Min. Product Length	• 4" Standard • 1.5" with optional closing conveyor	• 4" Standard • 2.75" with optional closing conveyor
Max. Product Length**	20"	31"
Conveyor Belt Width	14.5"	17"
Max. Film Width (Folded)	24"	30"
Max. Film Width (Flat)	42" with compact centerfolder	
Conveyor Height	Adjustable 31.5" – 37.5" without casters / 35.5" - 41.5" with casters	
Product Speeds***	Up to 35 packages per minute (standard)	
Longitudinal and Transverse Seal	Wide Fin Hot Knife	
Power	230V, 15 Amps, 60 Hz, 1 phase & other voltage options are available	
Compressed Air	0.5 C.F.M. free air at 60 psi	
Safety Devices	<ul style="list-style-type: none"> • Emergency stop button instantly stops all machine functions until manually reset • A transparent door, interlocked electrically with dual monitored safety circuit, covers the sealing area; door allows full access to the system when open • Tamper-resistant controls • Low voltage sensors and actuators • Film clamp proximity sensors ensure safe sealing arm jaw closure • UL certified electrical chassis 	

* Width plus height cannot exceed seal jaw width

** Length plus height cannot exceed seal jaw length

*** Dependent on product and application

USDA APPROVED MODELS ARE INDICATED WITH 'DA' IN THE MODEL NUMBER

© Reg. U.S. Pat. & TM Off.

A-26i/A-27i PLAN VIEW

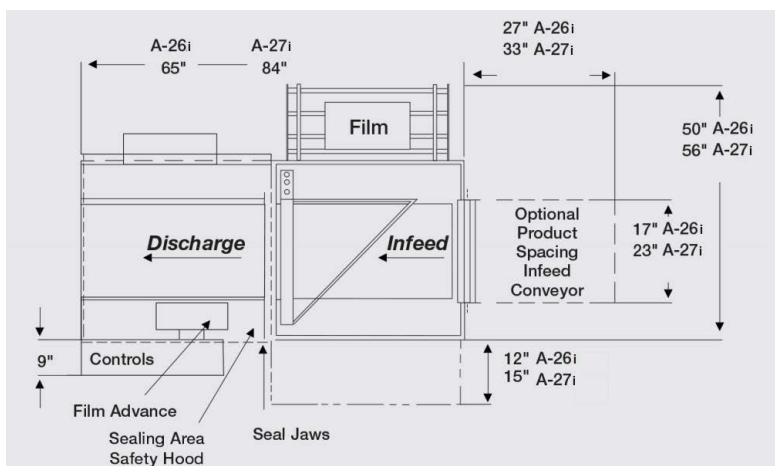

Meet the Shanklin® “A” Team

MODELS A-26i AND A-27i

The Shanklin® A-Series of compact, rugged and versatile Automatic Intuitive L-Sealers offers gentle product feed and straight line product flow ideal for handling a wide variety of products. A-Series machines feature simple to control conveyor-fed automatic operation, plus the L-Seal design provides great flexibility and quick product change via the picture-based touchscreen. Each will accept randomly spaced product, fed either automatically or by hand.

- **Easy to Use**—A picture-based HMI touchscreen allows operators to easily navigate the system controls and settings while corrective action screens offer recommendations to optimize system operation
- **Reliable**—Equipped with programmable controllers for simplicity of wiring and ease of troubleshooting; facilitates easy machine set up and adjustment
- **Flexible**—Photoelectric sensor system automatically compensates for package length change; automatic film advance system allows light, flexible products to be fed through the machine with ease
- **Versatile**—Easy and consistent product changeover by way of recipe parameters and the ability to handle virtually any type of film
- **Safe**—Electrical controls are UL-listed (for meeting the highest safety standards); sealing area is protected by an electrically interlocked transparent door through which the sealing process may be safely observed
- **Secure**—Features lock-outs and supervisor level logins to protect sensitive machine functions
- **Easy to Maintain**—EZ load unwind feature offers easy loading and threading capability; machine controls are located in front for quick and easy access

CORRECTIVE ACTION

All Ai systems utilize corrective action screens to guide an operator through a fault by both defining the fault and recommendations to recover from the fault.



STANDARD VALUE-ADDED FEATURES



New Guarding featuring Dual Monitored Safety Circuit



Intuitive Picture-Based Touchscreen



Automatic Film Puller



EZ Load Film Unwind

Shanklin® Automatic Intuitive L-Sealer

OPTIONS AT A GLANCE

By selecting just the right combination of options, you can customize your Shanklin® A-Series Automatic Intuitive L-Sealer for the ultimate performance, efficiency and value!

INFEED OPTIONS



Adjustable Flight Lug Infeed



72" Product Separating Infeed



Adjustable Flight Bar Infeed

AVAILABLE OPTIONS

OPTIONS	A-26i	A-27i
Adjustable Flight Bar Infeed Conveyor	X	X
Adjustable Flight Lug Infeed Conveyor	X	X
Product Separating Infeed Conveyor	X	X
Closing Discharge Conveyor	X	X
EZ Load Compact Centerfolder	X	X
Dual Roll Compact Centerfolder	X	X
Dual Infeed Eyes	X	X
Print Registration	X	X
Casters	X	X
EZ Film Thread Infeed Table	X	Standard
Large Capacity Selvage Winder	X	X
Stainless Steel Removable Infeed	X	X
Custom Options	X	X

For more information, please contact your Shanklin® distributor.

THE PERFECT PARTNER

Pair your Shanklin® Automatic L-Sealer with a Shanklin® Shrink Tunnel for superior wraps every time.





A TRADITION OF EXCEPTIONAL CRAFTSMANSHIP

Shanklin's® dedicated force of skilled craftsmen take pride in their ability to produce a truly superior product. Most of the specially manufactured parts that go into Shanklin® machines are produced in our own factory, and our extensive use of computer-controlled equipment ensures maximum quality and consistency at minimum cost.

Shanklin® machines are assembled by highly skilled technical professionals who excel at meeting our exacting specifications. Each machine is then carefully examined, tested and run in a typical application to ensure its optimum operation prior to shipping.

DOVERCO
Strategic. Packaging.

2111 32nd Avenue, Montreal, Quebec H8T 3J1
Tel: (514) 420-6060 • Fax: (514) 420-6015
250 Trowers Road, Unit 7, Vaughan, Ontario L4L 5Z6
Tel: (289) 256-2141 • Fax: (289) 256-2142
Toll Free: 1-800-363-0697 • www.doverco.ca • sales@doverco.ca