

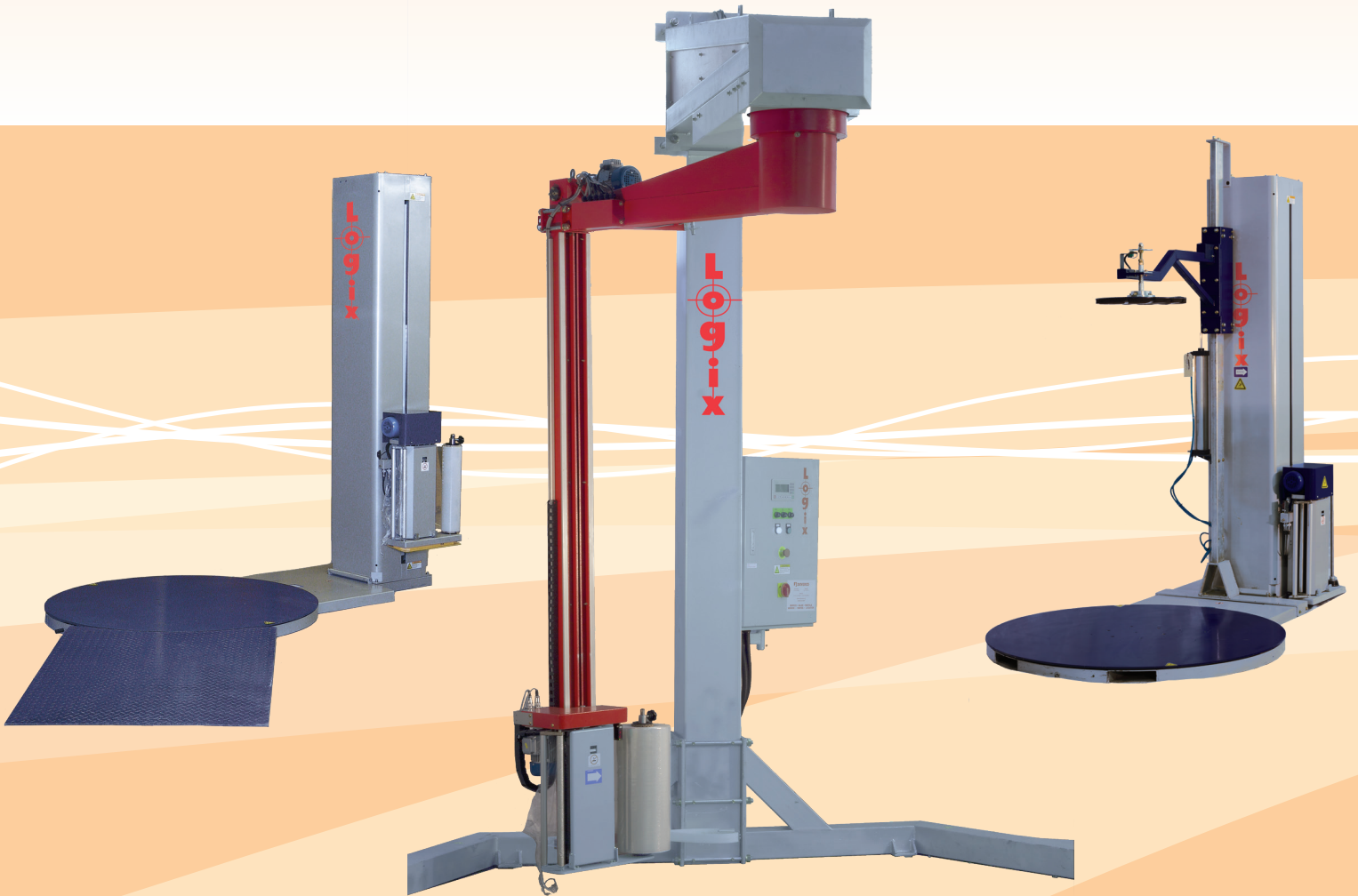

PAKWRAPPERS

Stretch Wrap Machinery



Why the PakWrapper?

- Simple, versatile and easy to use for all your wrapping needs
- Safely wraps up to 20 loads per hour
- Programmable...equipped with a photo-eye height sensor
- Pre-stretch carriage provides 200% film stretch
- 48 x 48" maximum pallet size

All Logix equipment is CSA or equivalent special inspection certified for insurance compliance liability.



Simple and easy adjustments

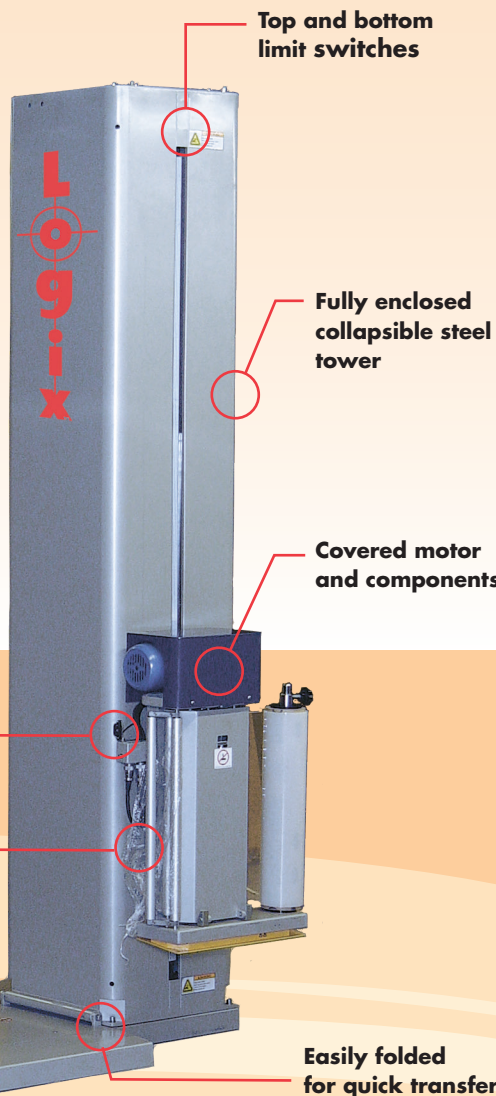

Top and bottom limit switches

Fully enclosed collapsible steel tower

Covered motor and components

Photo-electric eye

- Automatically senses and adjusts for the height of the load

Easy loading film carriage

Forklift slots

- Move the PakWrapper safely where you need it, when you need it!
- Movable from the front for easy positioning against a wall to minimize floor space use

Easily folded for quick transfer

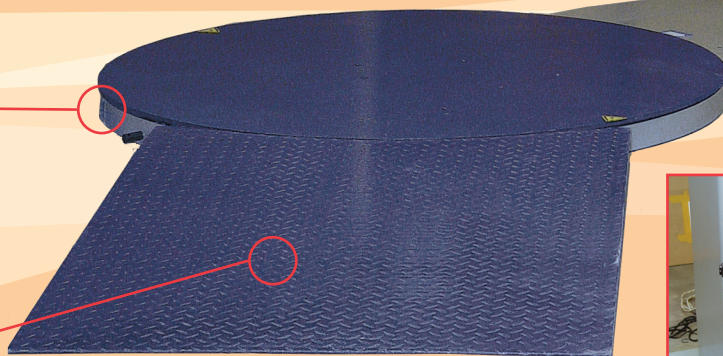

Optional easy loading ramp

- Can be installed anywhere around the turntable
- Gentle grade enables easy loading with a pallet truck

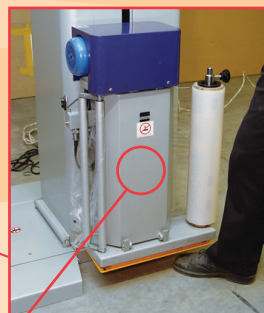

Safety Foot Sensor

- Stops the descent of the carriage if an object is detected underneath

Door monitoring safety switch

PakWrapper PW-6100

Extended Tower PakWrapper PW-6100-EX

- Loaded pallet capacity: 2,000 kg (4,400 lb); 48 x 48"
- Shown with optional ramp

Wrap height 106"

Wrap height 80"

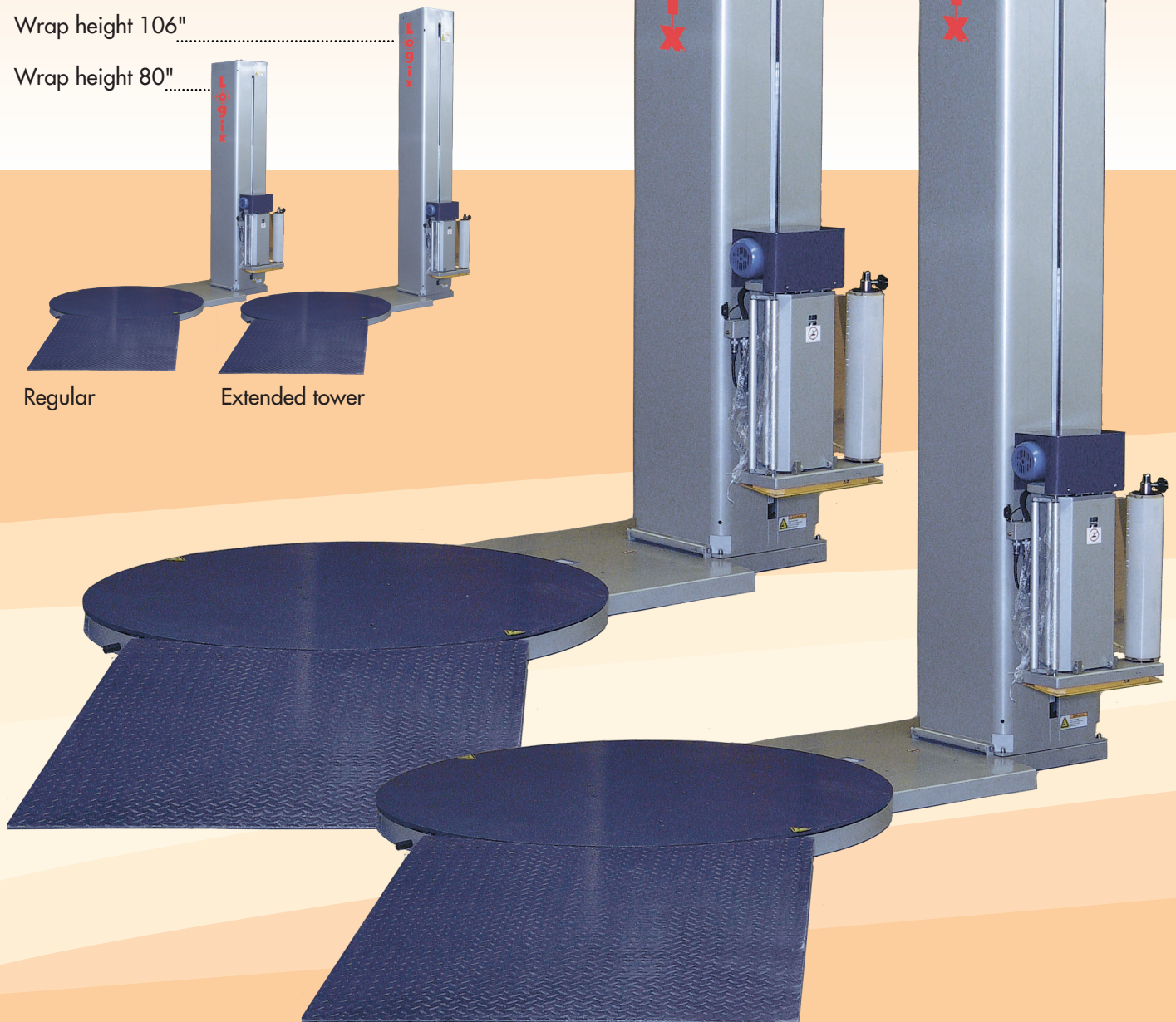

Regular

Extended tower

PakWrapper TOP PRESS PW-6100-TP

- The Top Press PakWrapper allows wrapping unstable loads or loads that have light items that require support
- All specifications as per the PW-6100
- Also available as extended tower model PW-6100-EX-TP



PakWrapper with Integrated Scale PW-6100-SC

- Improve profitability by combining two operations; wrap and pallet weighing
- All wrapper specifications as per the PW-6100
- Place the scale's moveable display on the post or on the wall as required
- Also available as extended tower model PW-6100-EX-SC
- Scale capacity: 1,500 kg (3307 lb)
- Scale precision: 100 g (1/4 lb)
- Forklift access only



PakWrapper Rotary Arm PW-8100

- Overhead rotary tower system wraps loads directly on the floor
- Designed for heavy or unstable loads
- Freestanding machine with front entrance
- Can be placed anywhere
- Programmable and equipped with a photo-eye height sensor
- Pre-stretch carriage
- Film can be pre-stretched up to 200%

Specifications:

Max diameter: 200 cm (80")

Max height: 200 cm (80")

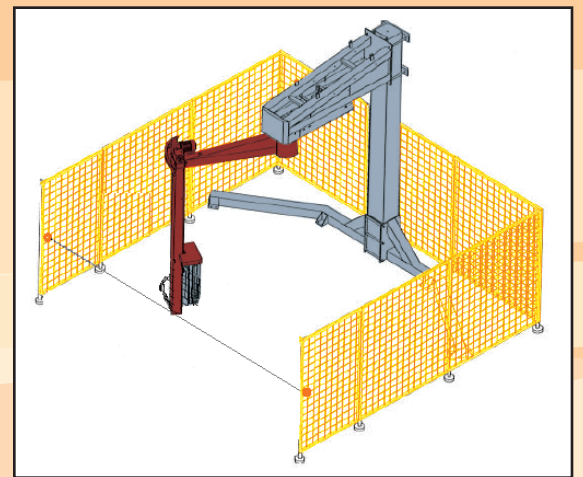

Yellow safety fencing optional

Value-added programs:

- ✓ Service 7 days a week, 24 hours a day
- ✓ Full warranty service
- ✓ Machine overhaul service
- ✓ Buyback programs

Plus...

- ✓ Experienced, factory trained technicians
- ✓ Stock parts & film inventory

Let Doverco make it easy for you

- ✓ 3rd party leasing
- ✓ Purchase through film usage
- ✓ Rental (with purchase option)
- ✓ Trade-ins

General Specifications:

Power: 1 phase; 110V; 60Hz

Optional Equipment



Extended Base - EB

- For extra wide or long loads (max. 8' (96") long)



Regular Ramp

PWR - 60" Length



Reinforced Ramp

PWRR - 78" Length

- For powered lift vehicles

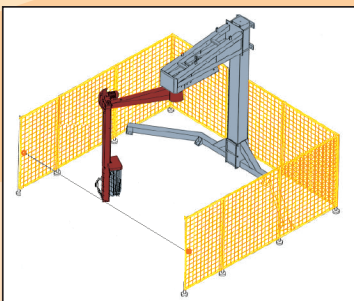

Yellow safety fencing for PW-8100



Film Specifications:

Core Diameter Capacity: 50-76 mm (2"-3")
Roll Weight maximum: 18 kg (40 lb)
Roll maximum width: 500 mm (20")

Your Packaging Equipment Specialists

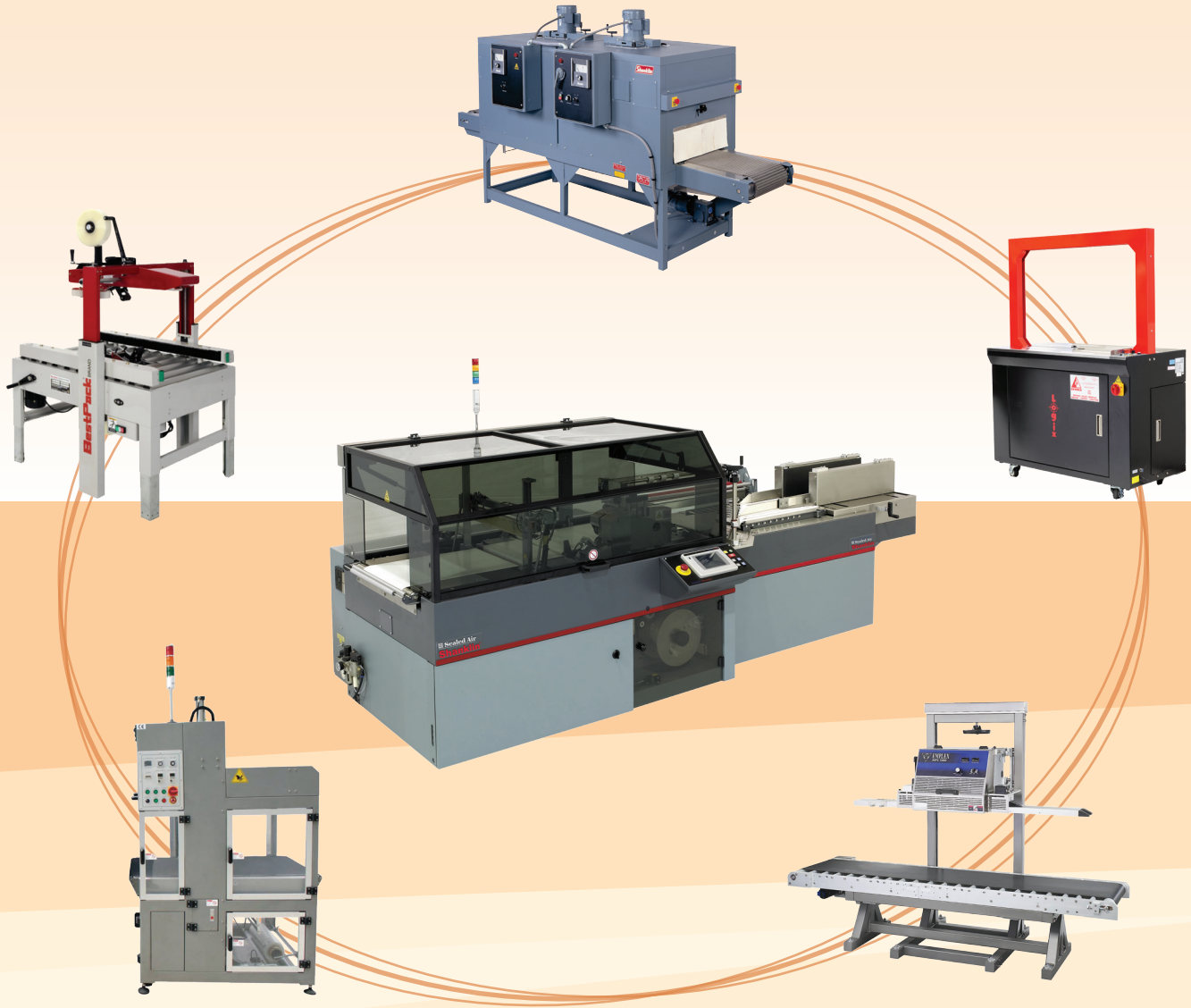

2111 32nd Avenue, Montreal, Quebec H8T 3J1
250 Trowers Road, Unit 7, Vaughan, Ontario L4L 5Z6

Toll free: Tel.: 1-800-363-0697 • Fax: 1-800-796-7526
Montreal: Tel.: (514) 420-6060 • Fax: (514) 420-6015
Vaughan: Tel.: (289) 256-2141 • Fax: (289) 256-2142

www.doverco.ca • sales@doverco.ca