

Industry Leader In Specialty, Modular Conveyor Solutions

*Quality, Low Profile Conveyors
With Short Lead Times.*

We Build Conveyors, You Reconfigure! 

DynaProTM Overview

Dynamic Conveyor introduced the DynaProTM line to meet the need for a durable, low profile conveyor that could be used across various industries and applications. Our expertise ensures the DynaProTM line meets the demand at an affordable price.

DynaProTM conveyors are an excellent solution to help companies achieve their energy and efficiency goals by using compact, high-efficiency 60w & 120w DC brushless motors. Over a one-year, single shift period, this saves an estimated 30% on energy costs over competitors' large, 3-phase AC motors.

DynaProTM conveyors feature tensionless link style belting to prevent tracking issues and allow for easy belt repair in lieu of replacing entire belts. Further, the DynaProTM incorporates many standard features that most other conveyors have as options. These standard features include variable speed, reversing, nose bar design for tight transfers, and an I/O receptacle for machine integration.

DynaProTM conveyors easily integrate into nearly any application and are an excellent complement to Dynamic Conveyor's other product lines.



Features	Benefits
Standardized Design & Components	Industry leading, 0 to 5-day lead time
Maintenance Free	Reduces cost of ownership & downtime
Tensionless Belts	Eliminates belt tracking issues
Standard High Efficiency Motors	Reduces energy consumption
Modular Plastic Link-Style Belting	Improves durability over standard fabric belting
Integration Package	Allows for easy machine integration
5-Year Warranty	Industry leading quality & reliability

TECH SPECS

Width

12", 18", 24", 30"

Length

3', 4', 6', 8', 10'

Drive Package

- Variable Speed, 0 - 100 ft Per Minute
- Reversing Capable
- I/O Receptacle

Belting

Small Pitch, Flat Top, Link Style Modular Belting

Leg Support

- Extruded Aluminum With Powder Coated Steel Sleeves
- Footpads
- Leg Height: 32" – 42" With Infinite Adjustment In Between
- Ability To Adjust Legs To Incline Conveyor

Materials

- High Density Polyethylene Sidewalls
- Extruded Aluminum Crossbars
- Polypropylene Belting

Load Capacity

- 135lbs Total Load Capacity

Motor

- External Mount 115v High Efficiency DC Brushless Motor
- 60w (3', 4' and 6')
- 120w (8' and 10')

Options*

- Friction Top Belting
- 2", 4", 6", 8" Sidewall Retaining Kits
- Feed End Retaining Kits
- Remote I/O Cable In 5, 10, 15m Lengths
- Casters

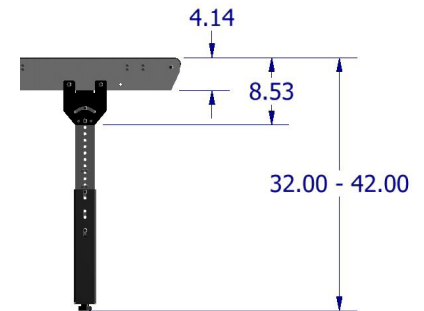

Adjustable leg height, bracket mounted option, floor mounted frame option.

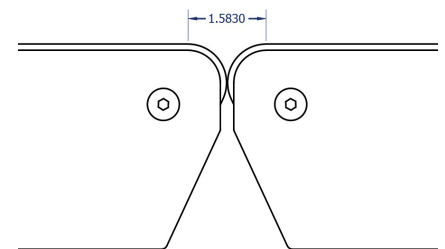

Distance between nosebar centers allows for tight transfer of products.

*Options and high-volume orders may extend lead times.

DOVERCO
Strategic. Packaging.

2111 32nd Avenue, Montreal, Quebec H8T 3J1
Tel: (514) 420-6060 • Fax: (514) 420-6015

250 Trowers Road, Unit 7, Vaughan, Ontario L4L 5Z6
Tel: (289) 256-2141 • Fax: (289) 256-2142

Toll Free: 1-800-363-0697 • www.doverco.ca • sales@doverco.ca